

OPERATION INSTRUCTION MANUAL
JOHNSON VIKING MATCHBOX
ANTENNA COUPLERS

These instructions are applicable for the installation and operation of the following Matchboxes:

- 250-23 Matchbox for use with transmitters which have a maximum input of 275 watts to the final amplifier.
- 250-23-3 Matchbox, similar to the 250-23 unit, with a directional coupler indicator installed and a Directional Coupler (part no. 250-37) furnished.
- 250-30 Matchbox for use with transmitters which have a maximum input of 1,000 watts to the final amplifier.
- 250-30-3 Matchbox, similar to the 250-30 unit, with a directional coupler indicator installed and a Directional Coupler (part no. 250-37) furnished.



E. F. JOHNSON COMPANY
WASECA, MINNESOTA, U. S. A. 56093

I. GENERAL DESCRIPTION

The Johnson Matchbox is an antenna coupler designed for matching antenna and transmission line impedances to a 52 ohm impedance within the amateur bands from 3.5 to 30 megacycles. The Matchbox also provides band switching and transfer of the coupler from transmitter to receiver and in addition mutes the receiver and grounds the receiver antenna terminals during transmission.

The Matchbox is capable of matching the 52 ohm coaxial output of a transmitter into loads ranging from approximately 50 ohms to 1200 ohms for balanced lines, and 50 to 2000 ohms for unbalanced lines. Large amounts of reactance can be compensated for by the coupler, the amount depending upon the frequency, line or antenna resistance. The Matchbox, or any coupler, installed at the transmitter end of the transmission line cannot correct the standing wave on the transmission line. This standing wave is a matter of impedance match between the antenna and the transmission line and may be eliminated in various ways described in antenna and transmission line literature.

The coupler circuit consists of a parallel resonant network utilizing an inductor with a coaxial wound coupling link, a dual tuning capacitor, and a dual differential matching capacitor as shown in Figure 1. Impedance matching for either balanced or unbalanced transmission lines and antennas is accomplished by the front panel controls of the two dual capacitors without resorting to the customary coil taps or link adjustments. Adjustment of the Matchbox must be accomplished by the use of a directional coupler, such as Johnson no. 250-37.

The Matchbox tuned circuit provides additional harmonic attenuation of the transmitter output by at least 15 db. The 52 ohm coaxial line between the transmitter and coupler provides for the insertion of a low pass (TVI) filter such as the Johnson 250-20 for improved harmonic attenuation. A terminal is provided on the terminal board for the installation of an R. F. probe for use with an oscilloscope, modulation indicator

The Kilowatt Matchboxes (part nos. 250-30 and 250-30-3) have a switching relay system designed for "fast make-slow break" operation allowing the final amplifier plate voltage to be cut off before the transmitter load is removed. The time of delay is fixed between .15 and .25 of a second which is ample to allow the relay contacts to break without any arcing.

II. INSTALLATION

The Matchbox and its Directional Coupler must be connected to the transmitter with a 52 ohm coaxial line as shown in Figure 2. The length of the coaxial line should be as short as practical since the input reactance varies more rapidly with frequency as the length of the line increases. If a low pass filter and a TR Switch are used, they should be installed as shown in Figure 2 using the coaxial lengths as indicated. The remaining connections to the Matchbox should be made as follows:

1. GROUND. This terminal should be connected to the ground terminal on the transmitter by means of a large gauge wire. The lead from the transmitter to ground should be a large gauge wire and as short as possible avoiding any lengths near an odd multiple of quarter-wave on the operating frequency. For multi-band operation, ground leads of various lengths should be installed.
2. RECEIVER ANTENNA. The antenna leads from the receiver should connect to the two terminals on the terminal board designated RECVR. ANT. Be sure the ground lead from the receiver is connected to the grounded antenna terminal. The Matchbox is supplied with the receiver tap at the 300 ohm position. Less turns will give a lower receiver antenna input impedance and vice versa.

3. R. F. PROBE. This probe may consist of a short piece of stiff self supported wire (soldered to the probe terminal inside the cabinet) with a small turn on the end to provide capacitive coupling to the coupler inductor. The coupling should be as loose as possible consistent with the energy needed so the coupler tank is not unbalanced.
4. RECEIVER CONTROL. These two terminals are connected to a normally closed contact on the relay and may be used to break the receiver B- voltage or muting circuit during transmission periods.
5. RELAY 115 V.A.C. The 115 volts AC for the antenna relay should be applied to these terminals. This voltage is usually secured and controlled from the exciter and should be applied to the relay only during transmitting periods.
6. BALANCED TWO WIRE LINE. The two feed-thru insulator terminals should be used for connecting all two wire balanced transmission lines. This applies to both the 275 watt and Kilowatt Matchboxes.
7. SINGLE WIRE.
 - a. 275 WATT MATCHBOX. This feed-thru insulator should be used for single wire transmission lines or the end of single wire antennas which are of high impedance.
 - b. KILOWATT MATCHBOX. Connect single wire transmission lines or the end of single wire antennas to the feed-thru terminal designated "SINGLE WIRE". The remaining feed-thru terminal must be grounded to the ground terminal above it during operation on 80, 40 and 20 meters and left ungrounded on 15, 11 and 10 meters.
8. COAXIAL AND LOW IMPEDANCE SINGLE WIRE.
 - a. 275 WATT MATCHBOX. If a coaxial line is used from the antenna, the inner conductor of the line should be attached to either of the two balanced line terminals, the outside conductor of the line grounded and the other balanced line terminal grounded throughout the range 3.5 to 30 megacycles.

Low impedance single wire transmission lines or antennas should be attached to either of the two balanced line terminals with the remaining balanced terminal connected to ground throughout the range 3.5 to 30 megacycles.
 - b. KILOWATT MATCHBOX. The coaxial line from the antenna must be connected to the coaxial terminal. The feed-thru insulator terminal with the ground terminal directly above it must be grounded during operation on 80, 40 and 20 meters and left ungrounded on 15, 11 and 10 meters.

Low impedance single wire transmission lines or antennas should be connected to the feed-thru terminal designated "SINGLE WIRE". The remaining feed-thru terminal must be grounded to the ground terminal above it during operation on 80, 40 and 20 meters and left ungrounded on 15, 11 and 10 meters.
9. DIRECTIONAL COUPLER. A directional coupler and its indicator must be used to properly tune the Matchbox and should be connected per the instructions received with it. The Johnson Directional Coupler, part no. 250-37, must be used with the end which has the white nylon tip jack, connected

to the 52 ohm coaxial line going to the Matchbox. The three indicator leads from the Matchbox (or from a separate Directional Coupler Indicator, Johnson part no. 250-38) should be connected to the Directional Coupler with the white, red and black colored plugs in their corresponding color tip jacks.

Unlike SWR Bridges which must be operated at very low power levels, the Directional Coupler may be left in the transmission line to furnish a continuous indication of SWR and relative power output while operating with power levels of up to 1000 watts input.

III. OPERATION

DO NOT ATTEMPT TO PLACE THE MATCHBOX IN OPERATION WITHOUT THOROUGHLY UNDERSTANDING THESE OPERATING INSTRUCTIONS AND ADJUSTING THE MATCHBOX ACCORDINGLY.

The following step-by-step tuning procedure should be performed only after the Matchbox has been connected in accordance with the preceding INSTALLATION section.

1. Turn the Matchbox BAND knob to the desired operating band.
2. Turn the Indicator Switch to CALIBRATE and rotate the Indicator Calibrate Control to minimum (full counter-clockwise on Johnson Indicators).
3. Adjust the transmitter final amplifier, with reduced output coupling, to a frequency in the same band as the Matchbox.
4. Adjust the Indicator Calibrate Control (clockwise rotation) to obtain a full scale Indicator Meter reading.
5. Rotate the Indicator Switch to SWR. If the Indicator Meter reads more than full scale, readjust the Indicator Calibrate Control until the meter reads full scale.
6. Alternately adjust the Matchbox "TUNING" and "MATCHING" dials until the indicator Meter reads minimum SWR. Keep the transmitter final amplifier in resonance (plate current dip) while tuning the Matchbox. As the Matchbox adjustments bring the impedance match closer to 52 ohms (SWR of 1 on the Indicator Meter), the reaction on the final amplifier will become less pronounced.
7. When the Indicator Meter indicates minimum SWR, turn the Indicator Switch to CALIBRATE and readjust, if necessary, the Indicator Calibrate Control until the meter reads full scale. Return the Indicator Switch to the SWR position.
8. Return the Matchbox for minimum SWR. Turn the Indicator Calibrate Control to minimum (full counter-clockwise position).
9. Adjust the loading and tuning of the transmitter final amplifier to the desired power input. DO NOT attempt to load the final amplifier by changing the Matchbox adjustments.
10. Turn Indicator Switch to CALIBRATE and advance the Indicator Calibrate Control for full scale reading on the Indicator Meter. Return the Indicator Switch to the SWR position. The meter now reads the actual SWR at full power input.
11. Record the Matchbox "TUNING" and "MATCHING" dial settings for future reference when returning to this frequency.
12. The operating frequency may be changed until a maximum SWR of 1.5 is indicated on the Indicator Meter at which frequency the Matchbox should be readjusted, per steps 1 through 10 above.

275 WATT MATCHBOX

Parts List

<u>Schematic No.</u>	<u>Part No.</u>	<u>Description</u>
C1	154-505-4	Condenser, 100ED30
C2	169-25	Condenser, 100EDA30
*C3, C4	22.1097	Capacitor, .01 mfd. disc ceramic
J1	22.746	83-1R coaxial receptacle
L1	23.1041	Inductor
*M1	22.1488	Meter, 100 ua.
*R1	22.1196-1	Potentiometer, 2000 ohm 1/4 watt
RY	22.906	Relay, 3PDT
SW1	22.884	Band Switch
*SW2	22.1444-1	Switch, SPDT
*P1	105-303-1	Plug, black nylon phone tip
*P2	105-301-1	Plug, white nylon phone tip
*P3	105-302-1	Plug, red nylon phone tip

* denotes additional components in 250-23-3 Matchbox.

KILOWATT MATCHBOX

Parts List

<u>Schematic No.</u>	<u>Part No.</u>	<u>Description</u>
C1	152-517-2	Condenser, 110CD70
C2	160-32	Condenser, 100CDA70
C3	22.1156	Capacitor, 16 mfd. 250 WVDC
*C4, C5	22.1097	Capacitor, .01 mfd. disc ceramic
J1, J2	22.746	83-1R coaxial receptacle
L1	236-511-1	INDUCTOR
*M1	22.1445-1	METER, 100 ua.
R1	22.887	Resistor, 18 ohm 2 watt
*R2	22.1196-1	Potentiometer, 2000 ohm 1/4 watt
RY	22.1153	Relay, 5000 ohm d.c.
SR	22.1009	Selenium rectifier, 35 ma.
SW1	23.1153	Band Switch
*SW2	22.1444-1	Switch, SPDT
*P1	105-303-1	Plug, black nylon phone tip
*P2	105-301-1	Plug, white nylon phone tip
*P3	105-302-1	Plug, red nylon phone tip

* denotes additional components in 250-30-3 Matchbox

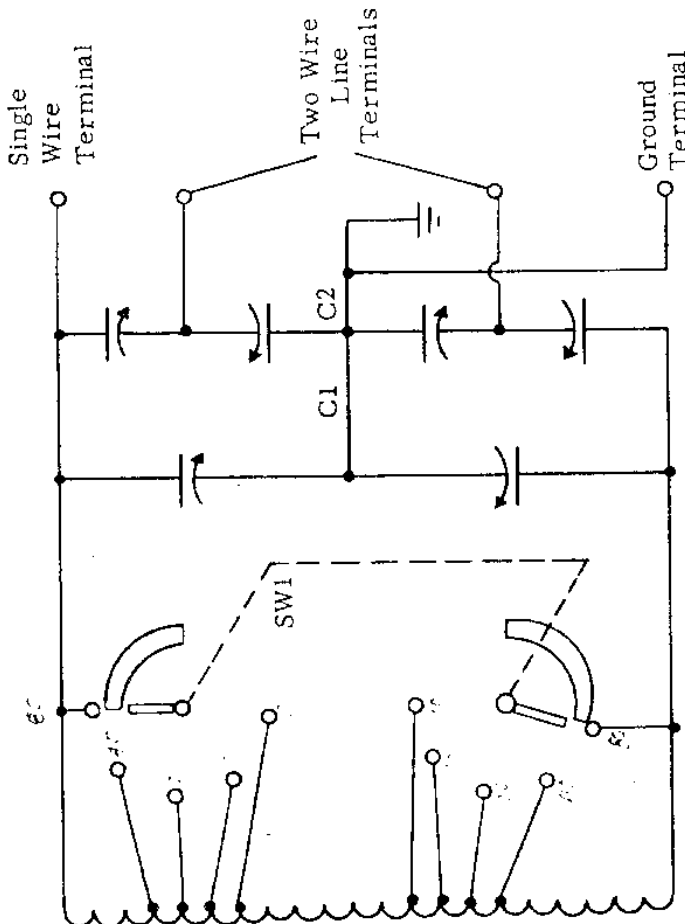

Relay, RY, shown in the transmit position

Band Switch, SW1, shown in the 80 Meter position

RF probe installed by operator according to coupling requirements

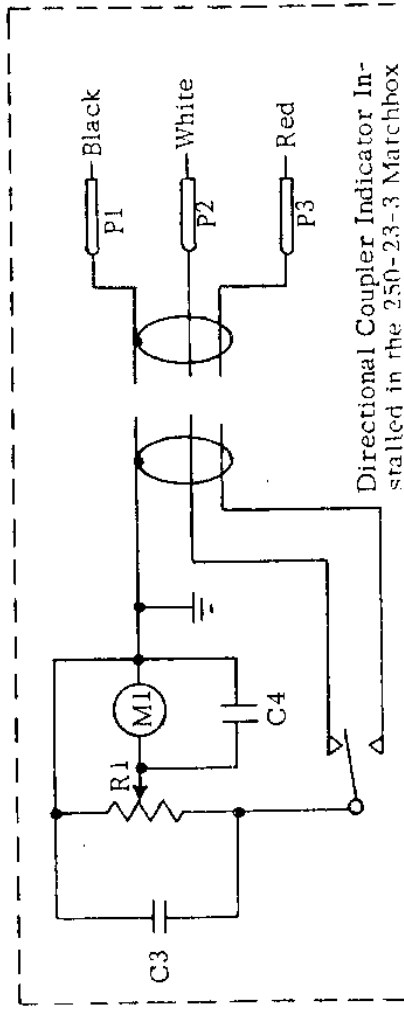
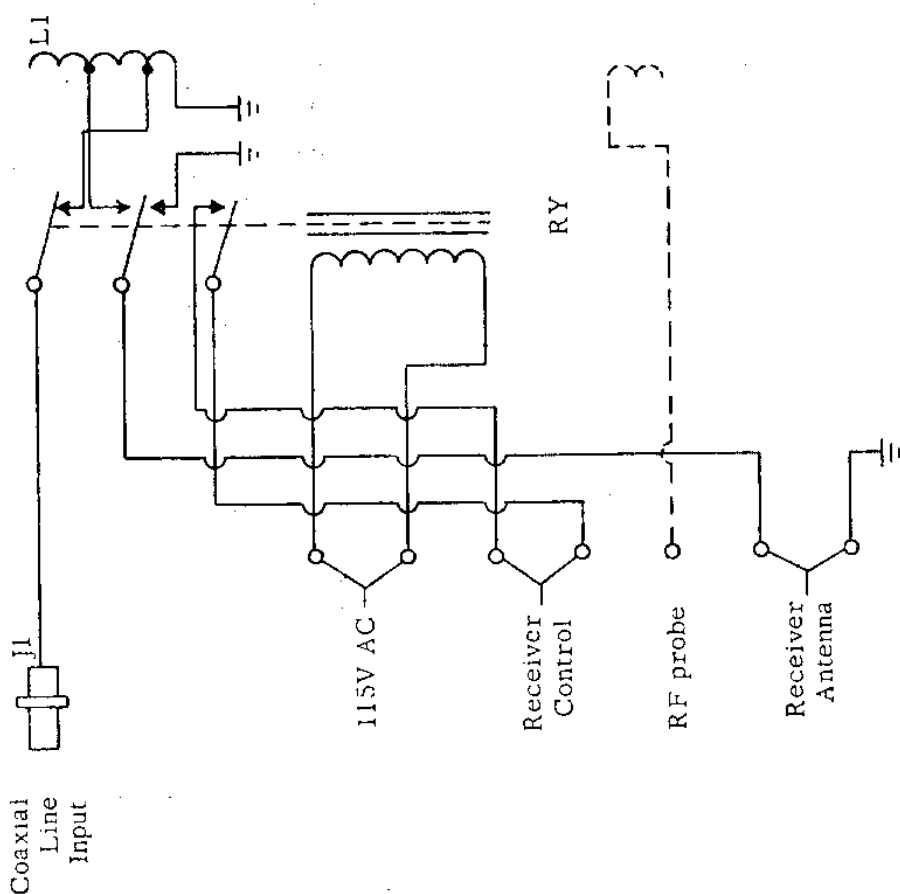

Directional Coupler Indicator Installed in the 250-23-3 Matchbox

FIGURE 1a
SCHEMATIC DIAGRAM
275 Watt Matchbox

Part Nos. 250-23
250-23-3

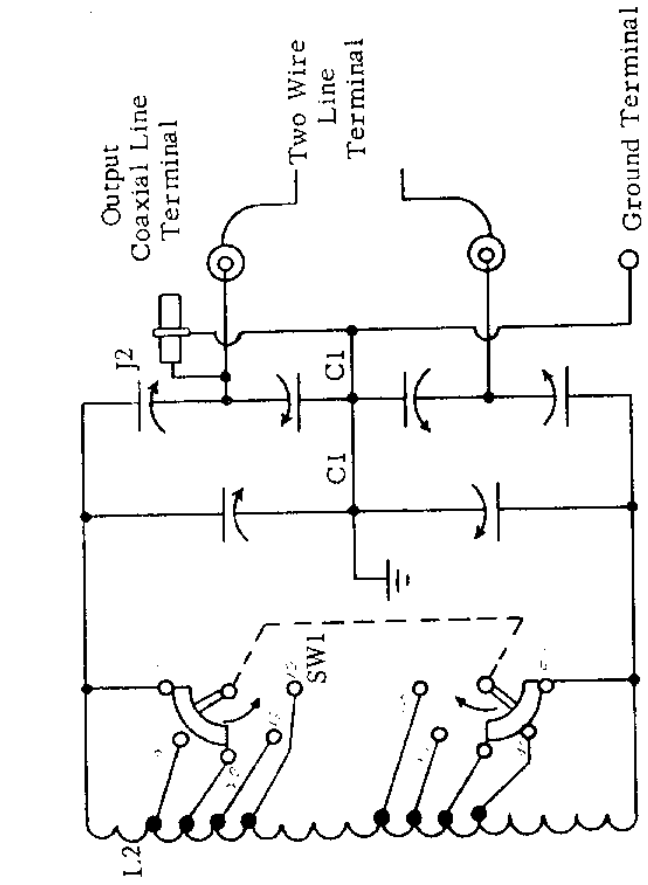

Relay, RY, shown in transmit position

Band Switch, SW1, shown in 20 Meter position

RF Probe installed by operator according to coupling requirements

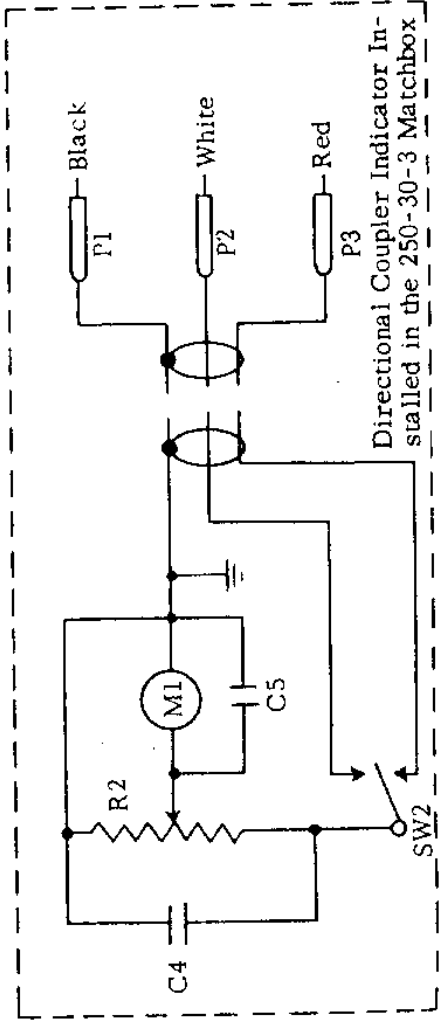
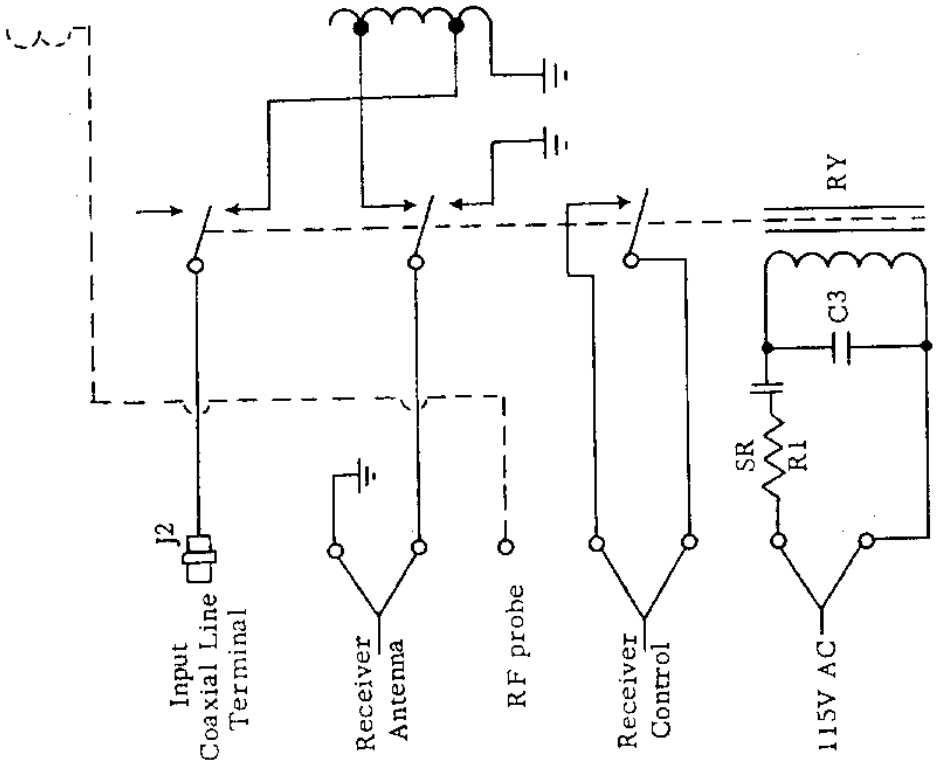

FIGURE 1b
SCHEMATIC DIAGRAM

Kilowatt Matchbox

Part No's 250-30
250-30-3

FIGURE 2

275 WATT TRANSMITTER - MATCHBOX INTERCONNECTION

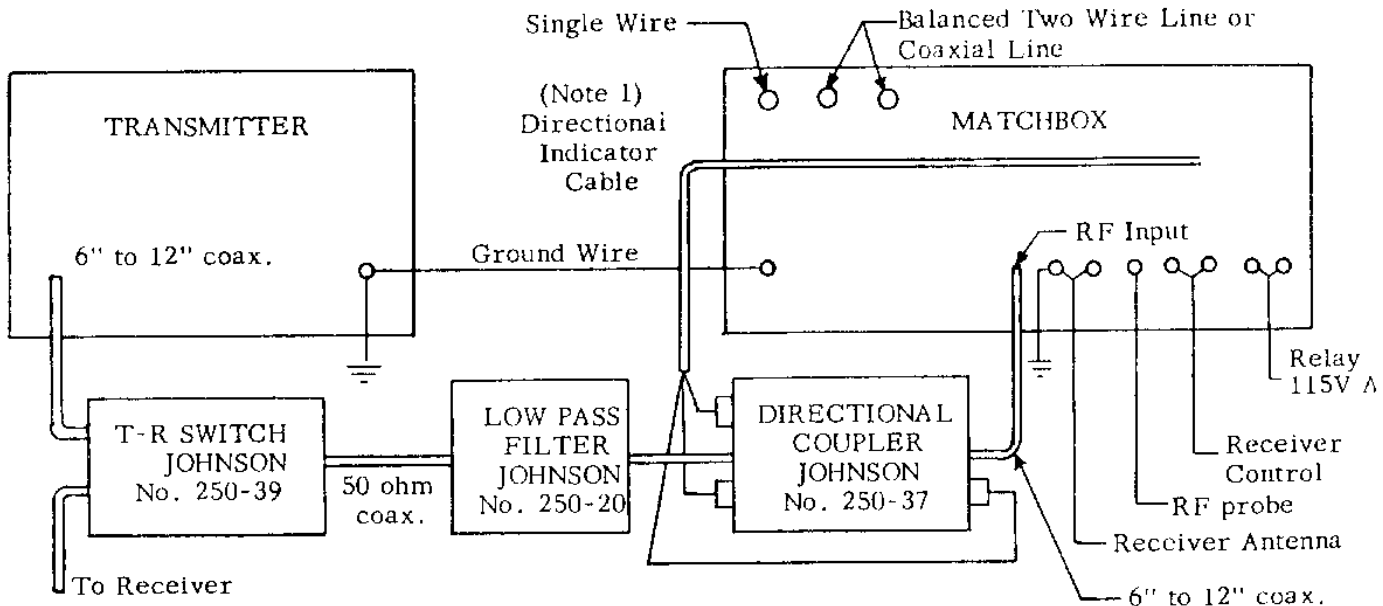

KILOWATT TRANSMITTER - MATCHBOX INTERCONNECTION

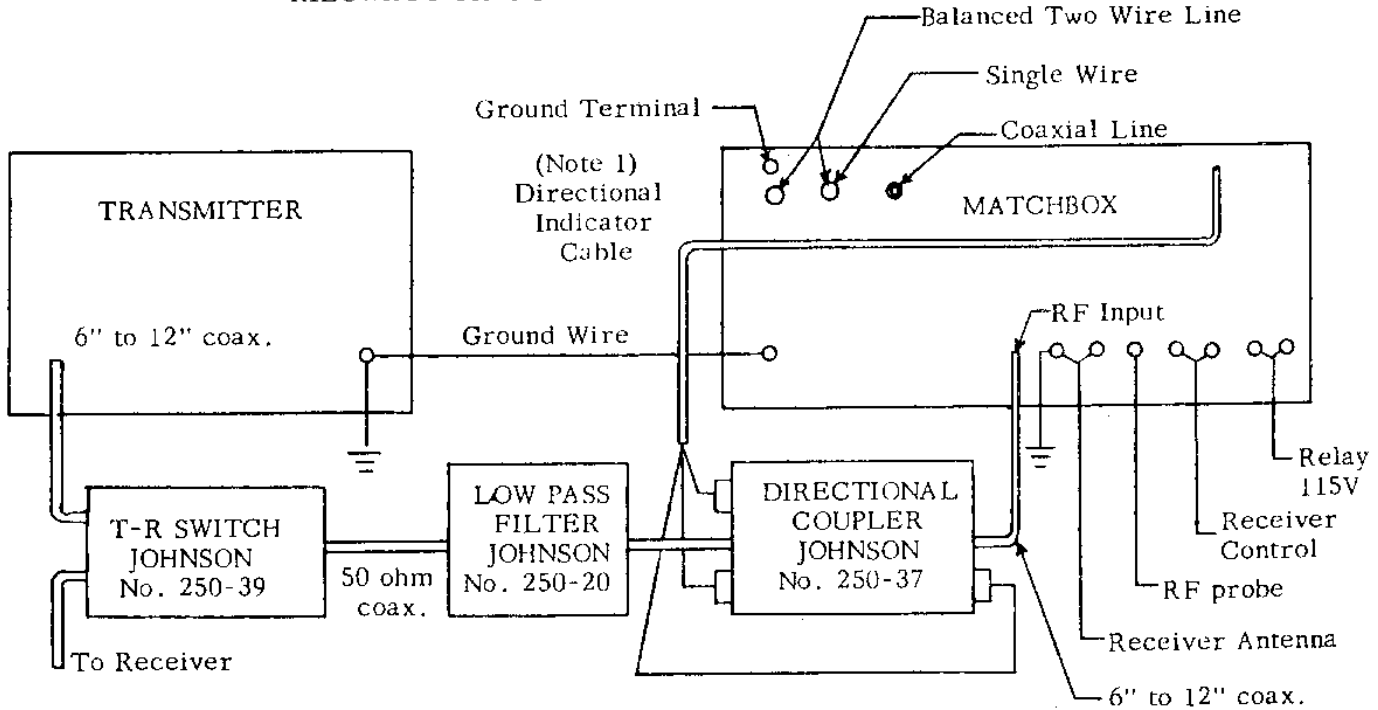

Note 1 - If a separate Directional Coupler Indicator is used, disregard the cable from the Directional Coupler to the Matchbox.

**OPERATING INSTRUCTIONS
JOHNSON DIRECTIONAL COUPLER
AND
DIRECTIONAL COUPLER INDICATOR**

Cat. No. 250-37 and 250-38

GENERAL DESCRIPTION

The JOHNSON Directional Coupler is a device designed primarily to measure standing wave ratio on 52 ohm coaxial transmission lines, unbalanced 52 ohm systems, antennas or other devices. The Directional Coupler is also essential to proper adjustment of an antenna coupler unit. It is not critical with respect to frequency and will give accurate measurements up to frequencies of 150 megacycles. The Coupler may be left in the transmission line to furnish a continuous indication of SWR and relative power output while operating with power levels of up to 1000 watts input.

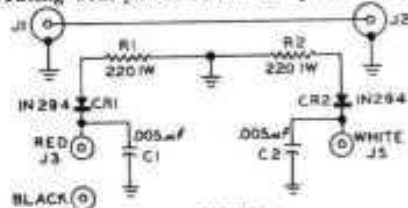

FIGURE 1
DIRECTIONAL COUPLER
SCHEMATIC

PARTS LIST

Symbol	Part No.	Description
C1, C2	22.327-1	Capacitor, .005 mfd ceramic disc
J1, J2	22.746	Connector, coaxial
J3	105-02-3	Tip Jack, Red nylon
J4	105-003-3	Tip Jack, Black nylon
J5	105-004-3	Tip Jack, White nylon
CR1, CR2	22.1413	Diode, Germanium 1N294
R1, R2	22.5031-10	Resistor, 220 ohm ± 10%, 1 watt

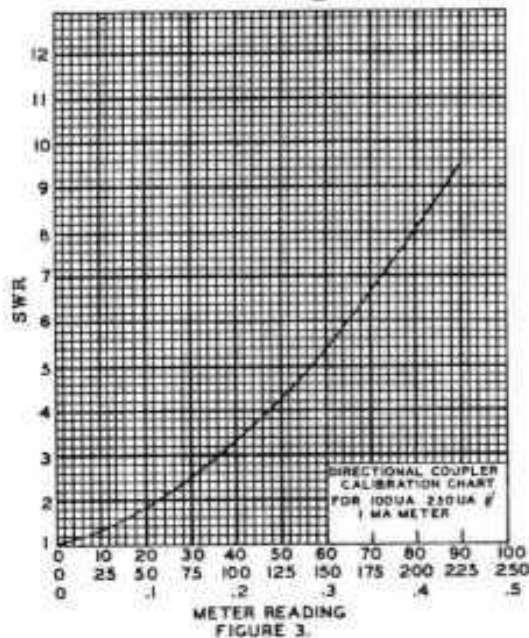

FIGURE 3.

CIRCUIT

The Directional Coupler is simply a short section of transmission line. Two indicating circuits placed back to back are coupled to the center conductor of the Coupler. The combination of inductive coupling and capacitive coupling is such that the incident power is cancelled out and the indicators measure relative reflected power. Since the indicators are back to back, one measures actual reflected power and the other measures actual incident power, which, because of its placement, appears to be reflected to that particular circuit. The ratio of reflected power to incident power is used to determine the SWR.

DIRECTIONAL COUPLER INDICATOR

The JOHNSON Directional Coupler Indicator, 250-38, is a 0-100 ua meter and associated circuitry which is housed in an attractive meter box. SWR may be read directly from the meter which is calibrated in SWR. A second scale calibrated in percent affords an indication of relative power output. If the JOHNSON Directional Coupler Indicator is not used in conjunction with the Directional Coupler, it will be necessary to use a 0-100 ua, 0-250 ua or 0-1 ma meter movement and connect it up in a circuit similar to the Directional Coupler Indicator as shown in Figure 2 below.

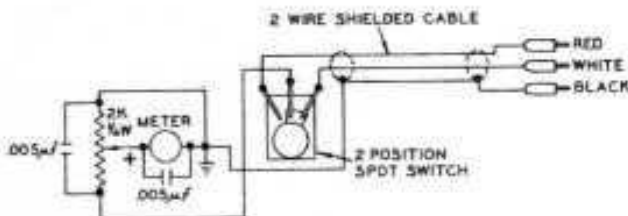

SCHEMATIC DIAGRAM, DIRECTIONAL COUPLER INDICATOR
FIGURE 2.

PARTS LIST

Part No.	Description
22.327-1	Capacitor, .005 mfd ceramic disc
22.1445-1	Meter, 100 ua.
22.1176-1	Potentiometer, 2000 ohm, 1/4 watt
105-301-1	Plug, white nylon phone tip
105-302-1	Plug, red nylon phone tip
105-303-1	Plug, black nylon phone tip
22.1444-1	Switch, SPDT

OPERATION

The operation of the Directional Coupler is very simple and straightforward. Connect the device to be measured to the coaxial connector which is located on the end of the Coupler which has the white nylon tip jack. Connect the RF power source to the coaxial connector on the end of the coupler which has the black and red nylon tip jacks. These ends are labeled reflected power and incident power, respectively. The power source may be any device in the 75 to 1000 watt input range.

E. E. JOHNSON COMPANY

WARREN, MINNESOTA, U. S. A.

It will also be necessary to have some type of meter to use as an indicator. If a JOHNSON Directional Coupler Indicator, 250-38, is used, merely plug the white, black and red nylon phone tip plugs on the indicator cable into the respective white, black and red phone tip jacks on the coupler. If the indicator is not used, a similar unit will have to be constructed as indicated in Figure 2 and the connections made to the coupler accordingly.

SWR MEASUREMENT

To read SWR, connect the coupler as indicated in the preceding paragraphs. Rotate the CALIBRATE control to minimum (full counter-clockwise on the JOHNSON Indicator) and the switch to CALIBRATE. Tune and load the transmitter. Adjust the CALIBRATE potentiometer to obtain a full scale meter reading except when using a 0-1 or 0-1.2 ma meter in which case adjust for .5 ma. Rotate the switch to the SWR position. The meter reading will drop if the SWR is less than 10 to 1. The JOHNSON Indicator indicates SWR directly. If an ordinary meter is being used, refer to the curves of SWR vs. meter readings, Figure 3, to obtain SWR.

Under certain power, frequency and SWR conditions, it may be impossible to obtain a full scale meter reading on a 250 ua meter and 0-1 ma meter. This is particularly true with low power, low frequency and low SWR conditions and is due to the fact that the Directional Coupler depends on inductive and capacitive coupling which at the lower power, frequency and SWR conditions are smaller. In this case, one will have to obtain a more sensitive meter such as the 0-100 ua or use the instrument to measure percent reflected power. Even though one cannot obtain full scale deflection in the CALIBRATE position, rotate the CALIBRATE potentiometer to obtain as large a reading as possible but set to a convenient value such as 150 ua, for instance. Then rotate the switch to SWR and read the reflected power reading. Multiply the reflected power reading by 100 and divide this number by the value obtained in the CALIBRATE position. Apply this resulting number to the 0-100 scale on the chart and read up to intersect the plotted line for SWR. For example if the reading in the CALIBRATE position was 150 ua and the reading in the SWR position was 22.5 ua, 22.5 divided by 150 equals .15 which is equivalent to an SWR of 1.5. There is a slight error introduced by the use of different power levels and whether the unknown impedance is more or less than 52 ohms. This error is negligible when the SWR is under 2.5 to 1 and amounts to less than 20% of the SWR in most other cases.

ANTENNA COUPLER ADJUSTMENT

The JOHNSON Directional Coupler may be used to properly adjust any antenna coupling unit including the Viking Matchbox coupler. It should be borne in mind that the antenna coupling unit is a device for matching or transforming the antenna system impedance (at the feed point) to the output impedance of the transmitter. The typical antenna coupler illustrated in Figure 4 is resonant at the operating frequency. The degree of coupling to the transmitter must be adjusted either by L_1 or some means within the transmitter such as a pi-network output circuit, variable link or other variable coupling device. The Directional Coupler should be installed between the power source and the antenna coupler input as in Figure 4.

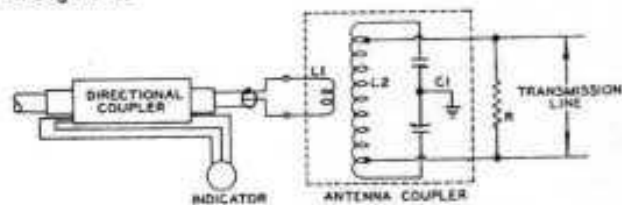

FIGURE 4

To adjust the antenna coupling unit for a minimum SWR, rotate the CALIBRATE control of the directional coupler indicator to its maximum counter-clockwise position and set the switch to CALIBRATE. Tune and load the transmitter to some value. Rotate the CALIBRATE potentiometer to obtain the usual calibrate dial reading which is full scale on all but the 0-1 ma meter. Rotate the switch to SWR, adjust the antenna coupler until the Indicator meter reads zero current which indicates that the antenna transmission line terminal impedance is matched into 52 ohms. If the antenna coupler has a circuit similar to the one shown, the coupler is adjusted to resonance by the tank capacitor C1 and the impedance matched by the taps on the coil L2. In some cases where the antenna and transmission line system present large values of reactance to the output terminals of the coupler, it will not be possible to attain a good impedance match since the SWR is high. In these cases, it is necessary to change the length of the antenna transmission line, or insert reactance of the sign necessary to cancel the antenna reactance. The JOHNSON Matchbox coupler is adjusted by two capacitor controls and will handle a large range of antenna resistances and reactances. After obtaining the lowest SWR, the transmitter may be loaded to its normal values.

MEASUREMENT OF RADIATION RESISTANCE OF AN UNBALANCED ANTENNA SUCH AS VERTICAL RADIATOR

Measurements must be made at the antenna terminals and not through a feed line. A variable capacitor and a variable inductor are required for tuning out antenna reactance. Ground the case of the Directional Coupler with the shortest possible lead. Connect the center terminal of the Directional Coupler output coaxial connector to the antenna to be measured with one of the variable reactances in series with the lead. With CALIBRATE control to minimum, tune and load the transmitter into the antenna to some convenient value. Set the CALIBRATE control to obtain the usual calibrate reading. Using first one reactance, then the other, adjust the capacitor or variable inductor until a minimum indicator meter reading is obtained. The reactance in the series lead will be equal but of opposite sign to the reactance of the antenna jX . If it is possible to measure the inductor or capacitor which produced minimum SWR one may calculate the amount of reactance. If the capacitor was used, $jX = \frac{1}{2\pi fC}$ and jX is inductive. If the inductor was used, $jX = 2\pi fL$ and jX is capacitive. Refer the minimum meter reading to the SWR vs. meter current chart, Figure 3, which will give the SWR. In the case of antennas where the antenna resistance is greater than 52 ohms, antenna resistance is equal to the product of the SWR and the standard resistance of 52 ohms. If the antenna resistance is less than 52 ohms, then antenna resistance is equal to 52 divided by the SWR. One may add a non-inductive resistor (less than 10 ohms) in series with the bridge center output terminal in order to determine whether the impedance is above or below 52 ohms. If the SWR increases with the addition of the resistor the unknown antenna resistance is greater than 52 ohms. If it decreases, the antenna resistance is smaller than 52 ohms.

MEASUREMENT OF TRANSMITTER INPUT IMPEDANCES

The JOHNSON Directional Coupler Indicator and JOHNSON Directional Coupler may be used to measure the input impedance of typical high power amplifiers. Connect the output connector of the Directional Coupler to the circuit to be measured. Tune and load the driving source to obtain the usual amount of grid current in the amplifier which is to be measured. Adjust the CALIBRATE potentiometer to obtain the usual calibrate reading, rotate the switch to SWR and read SWR of the transmitter input circuit. This is particularly convenient in measuring input circuits of linear and Class C amplifiers and will help in the adjustment of these circuits to obtain nominal 50 ohm input impedances.